



IGS-9084GP-FB2 Series

IGS-9084GP-FB2 Series

➤ **Industrial 12-port managed Gigabit bypass Ethernet switch with 8x10/100/1000Base-T(X) and 4x100/1000Base-X, SFP socket, LC connector bypass**

Features

- Supports **O-Ring** (recovery time < 30ms over 250 units of connection) and MSTP(RSTP/STP compatible) for Ethernet Redundancy
- **Open-Ring** support the other vendor's ring technology in open architecture
- **O-Chain** allow multiple redundant network rings
- Support standard IEC 62439-2 **MRP*NOTE** (Media Redundancy Protocol) function
- Support IEEE 1588v2 clock Synchronization
- Supports IPV6 new internet protocol version
- Support Modbus TCP protocol
- Provided HTTPS/SSH protocol to enhance network security
- Support IEEE 802.3az **Energy-Efficient Ethernet** technology
- Supports SMTP client
- Supports IP-based bandwidth management
- Supports application-based QoS management
- Supports Device Binding security function
- Supports DOS/DDOS auto prevention
- IGMP v2/v3 (IGMP snooping support) for filtering multicast traffic
- Supports SNMP v1/v2c/v3 & RMON & 802.1Q VLAN Network Management
- Support ACL, TACACS+ and 802.1x User Authentication for security
- Supports 9.6K Bytes Jumbo Frame
- Support 100M/1G/10G optical bypass function of 2 port duplex or 4 port simplex fiber connection
- Bypass switching time < 10ms and throughput not affected and no extra delay
- Multiple notification for warning of unexpected event
- Web-based ,Telnet, Console (CLI), and Windows utility (Open-Vision) configuration
- Support LLDP Protocol
- Rigid IP-30 housing design
- DIN-Rail and wall mounting enabled
- Supports backup unit device **DBU-01** to quickly configuration backup/restore



Introduction

IGS-9084GP-FB2 Series is managed redundant ring Ethernet switch with 8x10/100/1000Base-T(X) ports and 4x100/1000Base-X SFP ports and provided 4xLC connector optical bypass function. These fiber optical bypass switch protect the network from failures and Network maintenance by ensuring network integrity during power loss. With completely support of Ethernet Redundancy protocol, O-Ring (recovery time < 30ms over 250 units of connection) and MSTP (RSTP/STP compatible) can protect your mission-critical applications from network interruptions or temporary malfunctions with its fast recovery technology. And support wide operating temperature from -40 to 75°C. IGS-9084GP-FB2 Series can also be managed centralized and convenient by Open-Vision, Except the Web-based interface, Telnet and console (CLI) configuration. Therefore, the switch is one of the most reliable choice for highly-managed and Fiber Ethernet application.

*NOTE: This function is available by request only

- **O-Ring** : O-Ring is ORing's proprietary redundant ring technology, with recovery time of less 30 milliseconds and up to 250 nodes. The O-Ring redundant ring technology can protect mission-critical application from network interruptions or temporary malfunction with its fast recovery technology.
- **Open-Ring** : Open-Ring is an enhanced redundant technology that makes ORing's switches compatible with other vendor's proprietary redundant ring technologies. It enables ORing's switches to form a single ring with other vendor's switch. In cases where the ring is setup using proprietary technology, ORing offers a compatibility service where ORing can make its switches compatible with your particular network requirements.
- **O-Chain** : O-Chain is the revolutionary network redundancy technology that provides the add-on network redundancy topology for any backbone network, O-Chain allows multiple redundant network rings of different redundancy protocols to join and function together as a larger and more robust compound network topology. O-Chain providing ease-of-use while maximizing fault-recovery swiftness, flexibility, compatibility, and cost-effectiveness in one set of network redundancy topology.
- **MRP^{NOTE}** : Media Redundancy Protocol (MRP) is a data network protocol standardized by the IEC 62439-2. It allows rings of Ethernet switches to overcome any single failure with recovery time much faster than achievable with Spanning Tree Protocol.
- **IP-based Bandwidth Management** : The switch provide advanced IP-based bandwidth management which can limit the maximum bandwidth for each IP device. User can configure IP camera and NVR with more bandwidth and limit other device bandwidth.
- **Application-Based QoS** : The switch also support application-based QoS. Application-based QoS can set highest priority for data stream according to TCP/UDP port number.
- **Device Binding Function** : ORing special Device Binding function can only permit allowed IP address with MAC address to access the network. Hacker cannot access the IP surveillance network without permission. It can avoid hacker from stealing video privacy data and attacking IP camera, NVR and controllers.
- **Advanced DOS/DDOS Auto Prevention** : The switch also provided advanced DOS/DDOS auto prevention. If there is any IP flow become big in short time, the switch will lock the source IP address for certain time to prevent the attack. It's hardware based prevention so it can prevent DOS/DDOS attack immediately and completely.
- **IEEE 1588v2 Technology** : The IEEE 1588v2 technology can fulfill precision time synchronization requirements for protection and control applications.
- **Modbus TCP** : This is a Modbus variant used for communications over TCP/IP networks.
- **IEEE 802.3az Energy-Efficient Ethernet** : This is a set of enhancements to the twisted-pair and backplane Ethernet family of networking standards that will allow for less power consumption during periods of low data activity. The intention was to reduce power consumption by 50% or more.

*NOTE: This function is available by request only

Tunnel Application

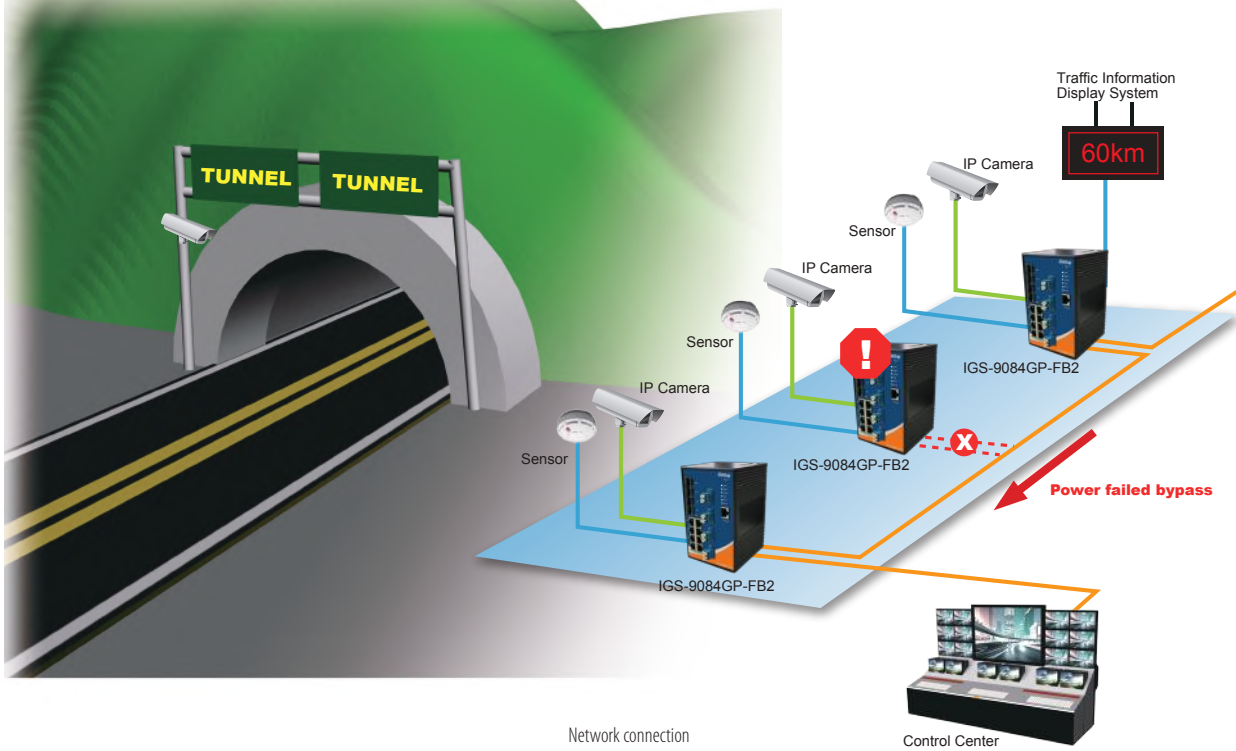

Industrial Ethernet Switch

Optical Bypass Operation

Normal mode:

The Bypass switch diver the data from the Network ports data to the Monitor ports

Bypass mode:

The Network data traffic routed directly to the other Network port. And the Monitor data traffic routed directly to the other Monitor port.

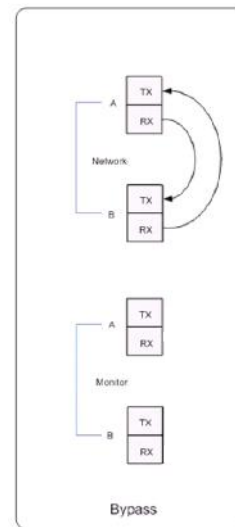
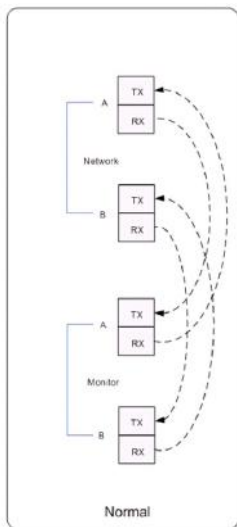

Open-Vision

ORing's switches are intelligent switches. Different from other traditional redundant switches, ORing provides a set of Windows utility (Open-Vision) for user to manage and monitor all of industrial Ethernet switches on the industrial network.

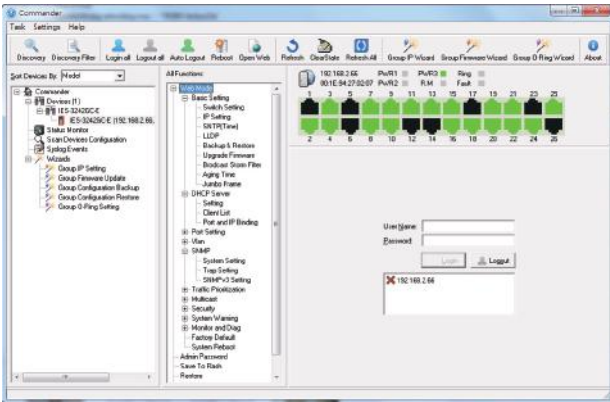

Commander

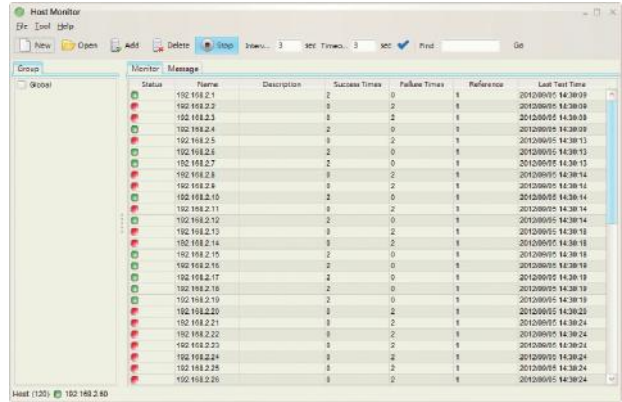

Host Monitor

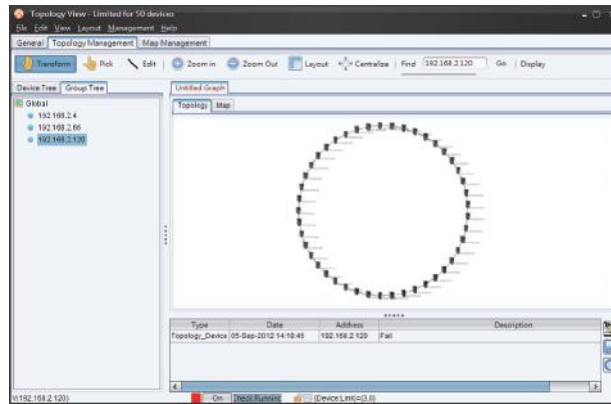

Topology View

Dimensions

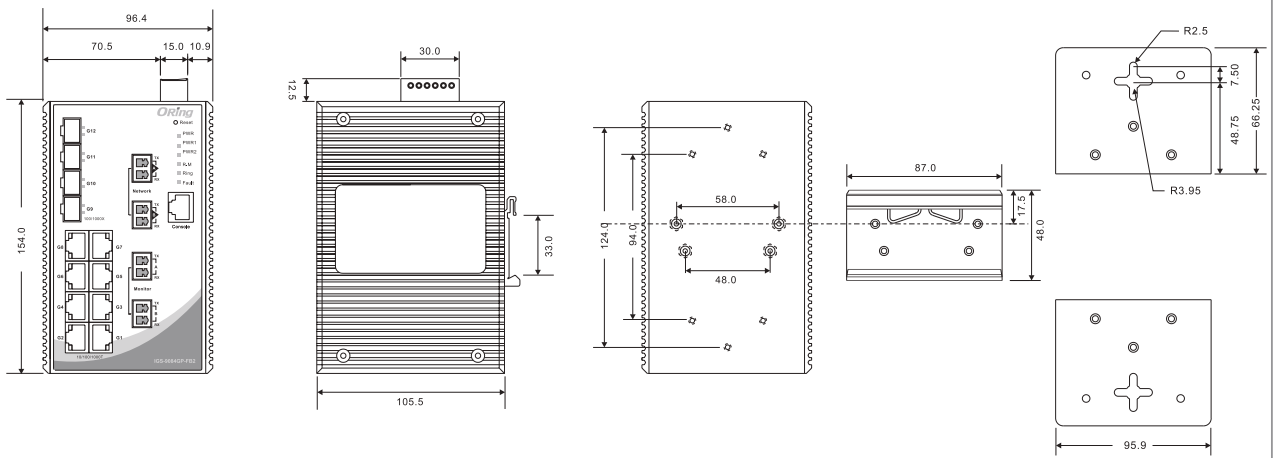

(Unit=mm)

- Industrial Ethernet Switch
- Industrial Media Converter
- Industrial Device Server
- Industrial Wireless Access Point
- Industrial Cellular VPN Router
- Industrial M2M Gateway
- Accessories
- Network Management Software

Specifications

ORing Switch Model	IGS-9084GP-FB2-SS	IGS-9084GP-FB2-MM
Physical Ports		
10/100/1000Base-T(X) Ports in RJ45 Auto MDI/MDIX	8	
100/1000Base-X SFP Port	4	
LC Bypass Port Type	Single-Mode	Multi-Mode
Technology		
Ethernet Standards	IEEE 802.3 for 10Base-T IEEE 802.3u for 100Base-TX and 100Base-FX IEEE 802.3ab for 1000Base-T IEEE 802.3z for 1000Base-X IEEE 802.3x for Flow control IEEE 802.3ad for LACP (Link Aggregation Control Protocol) IEEE 802.1p for COS (Class of Service) IEEE 802.1Q for VLAN Tagging IEEE 802.1w for RSTP (Rapid Spanning Tree Protocol) IEEE 802.1s for MSTP (Multiple Spanning Tree Protocol) IEEE 802.1x for Authentication IEEE 802.1AB for LLDP (Link Layer Discovery Protocol)	
MAC Table	8K	
Priority Queues	8	
Processing	Store-and-Forward	
Switch Properties	Switching latency : 7 μ s Switching bandwidth : 24Gbps Max. Number of Available VLANs : 4095 VLAN ID Range : 1 to 4094 IGMP multicast groups: 256 for each VLAN Port rate limiting: User Define	
Jumbo frame	Up to 9.6K Bytes	
Security Features	Device Binding security feature Enable/disable ports, MAC based port security Port based network access control (802.1x) VLAN (802.1Q) to segregate and secure network traffic Radius centralized password management SNMPv3 encrypted authentication and access security Https / SSH enhance network security	
Software Features	STP/RSTP/MSTP (IEEE 802.1D/w/s) Redundant Ring (O-Ring) with recovery time less than 30ms over 250 units TOS/Diffserv supported Quality of Service (802.1p) for real-time traffic VLAN (802.1Q) with VLAN tagging IGMP Snooping IP-based bandwidth management Application-based QoS management DOS/DDOS auto prevention Port configuration, status, statistics, monitoring, security DHCP Server/Client/Relay SMTP Client Modbus TCP	
Network Redundancy	O-Ring Open-Ring O-Chain MRP**NOTE MSTP (RSTP/STP compatible)	
RS-232 Serial Console Port	RS-232 in RJ45 connector with console cable. 115200bps, 8, N, 1	
Switch LED indicators		
Power Indicator (PWR/1/2)	Green : Power LED x 3	
R.M. indicator (R.M.)	Green : indicate system operated in O-Ring Master mode	
Ring indicator (Ring)	Green : indicate system operated in O-Ring mode	
Fault indicator (Fault)	Amber : Indicates unexpected event occurred	
10/100/1000Base-T(X) RJ45 port indicator	Green for Link/Act indicator. Amber for duplex indicator	

*NOTE: This function is available by request only

100/1000Base-X SFP Port Indicator	Green for port Link/Act.
Fault Contact	
Relay	Relay output to carry capacity of 1A at 24VDC
Power	
Redundant Input Power	Dual DC inputs. 12~48 VDC on 6-pin terminal block
Power Consumption (Typ.)	13 Watts
Overload Current Protection	Present
Physical Characteristics	
Enclosure	IP-30
Dimensions (W x D x H)	96.4 (W) x 105.5 (D) x 154 (H) mm(3.8 x 4.15 x 6.06 inch)
Weight (g)	1205 g
Environmental	
Storage Temperature	-40 to 85°C (-40 to 185°F)
Operating Temperature	-40 to 75°C (-40 to 167°F)
Operating Humidity	5% to 95% Non-condensing
Regulatory Approvals	
EMI	FCC Part 15, CISPR (EN55022) class A
EMS	EN61000-4-2 (ESD), EN61000-4-3 (RS), EN61000-4-4 (EFT), EN61000-4-5 (Surge), EN61000-4-6 (CS), EN61000-4-8, EN61000-4-11
Shock	IEC60068-2-27
Free Fall	IEC60068-2-32
Vibration	IEC60068-2-6
Safety	EN60950-1
Warranty	5 years

Ordering Information

IGS-9 **AA** **B** **CC**-FB2-**DD**-LC

Code Definition	10/100/1000Base-T(X) Port Number	Additional Port Number	Additional Port Type	Fiber Optical Mode
Option	- 08 : 8 ports	- 4 : 4 ports	- GP : Gigabit SFP ports	- MM : Multi-mode - SS : Single-mode

Available Model	Model Name	Description
	IGS-9084GP-FB2-MM-LC	Industrial 12-port managed Gigabit Ethernet switch with 8x10/100/1000Base-T(X) and 4x100/1000Base-X, SFP socket
	IGS-9084GP-FB2-SS-LC	Industrial 12-port managed Gigabit bypass Ethernet switch with 8x10/100/1000Base-T(X) and 4x100/1000Base-X, SFP socket, single-mode LC connector bypass

Packing List

- IGS-9084GP
- DIN-Rail Kit
- Wall-mount Kit
- Console Cable
- ORing Tool CD
- Quick Installation Guide

Optional Accessories (Can be purchased separately)

- Open-Vision M500, Powerful Network Management Windows Utility Suite, 500 IP devices
- SFP100 series, 100Mbps SFP optical transceiver
- SFP1G series, 1Gbps SFP optical transceiver
- DR-45 series, 45W DIN-Rail power supply
- DR-75 series, 75W DIN-Rail power supply
- DR-120 series, 120W DIN-Rail power supply
- DBU-01 : Data backup unit device

Industrial Ethernet Switch
Industrial Media Converter
Industrial Device Server
Industrial Wireless Access Point
Industrial Cellular VPN Router
Industrial M2M Gateway
Accessories
Network Management Software